



REFRIGERATION

SERVING THE FOOD INDUSTRY SINCE 1951

# REFRIGERATED SALAD BAR / COLD FOOD TABLE

ITEM:	50089	50090
MODEL:	PT-CN-1524-S-HC	PT-CN-1778-S-HC



50089 60"

50090 72"

GET AMPLE STORAGE & SPACE WITH

## OMCAN'S REFRIGERATED PREP TABLES



**WARRANTY**  
PARTS AND LABOR

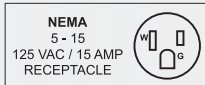

Authorized Dealer

# 60" REFRIGERATED SALAD BAR / COLD FOOD TABLE



## TECHNICAL DRAWINGS & DIMENSIONS

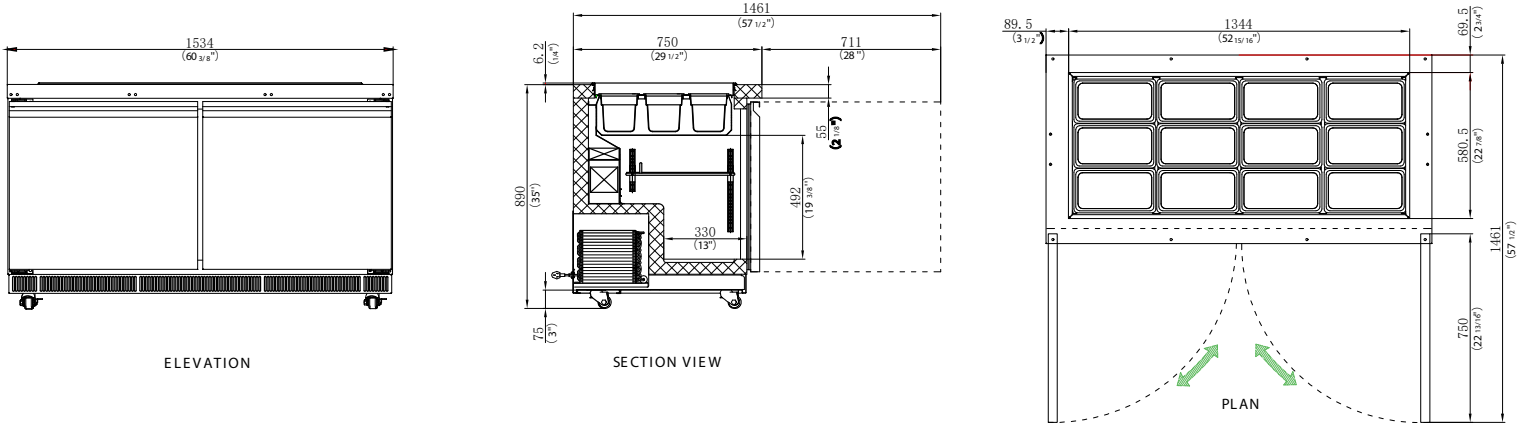

## TECHNICAL SPECIFICATIONS

ITEM	50089
MODEL	PT-CN-1524-S-HC
ELECTRICAL	110 V / 60 Hz / 1 Ph
POWER & AMPS	540 W   5.4 Amps
REFRIGERANT	R290
MAX. AMBIENT TEMPERATURE	24°C   75°F
TEMPERATURE RANGE	-0.5 to 0.5°C   31 to 33°F
ISOLATION MATERIAL	Cyclopetane
COOLING SYSTEM	Ventilated
NUMBER OF DOORS/SHELVES	2   2
CAPACITY	469 lit. / 16.6 cu. ft.
SHELF CAPACITY	27.4" x 17.1" (x2)   695 x 434 mm (x2)
WEIGHT	341.7 lb.   155 kg.
GROSS WEIGHT	412.3 lb.   187 kg.
DIMENSIONS	60.4" x 29.5" x 34.6"   1535 x 750 x 880 mm
INTERIOR DIMENSIONS	56.4" x 19.8" x 20"   1433 x 503 x 507 mm
GROSS DIMENSIONS	63" x 32.3" x 43.7"   1600 x 820 x 1110 mm



### Includes:

- Sneeze guard
- Tray slide
- Plastic basin cover
- 12 x 1/3 GN pans or 4 x 1/1 GN pans

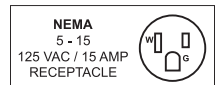

## OMCAN INC.

Telephone: 1-800-465-0234  
 Fax: (905) 607-0234  
 Email: sales@omcan.com  
 Website: www.omcan.com



Follow us to keep up to date with the latest news and offers



# 72" REFRIGERATED SALAD BAR / COLD FOOD TABLE



## TECHNICAL DRAWINGS & DIMENSIONS

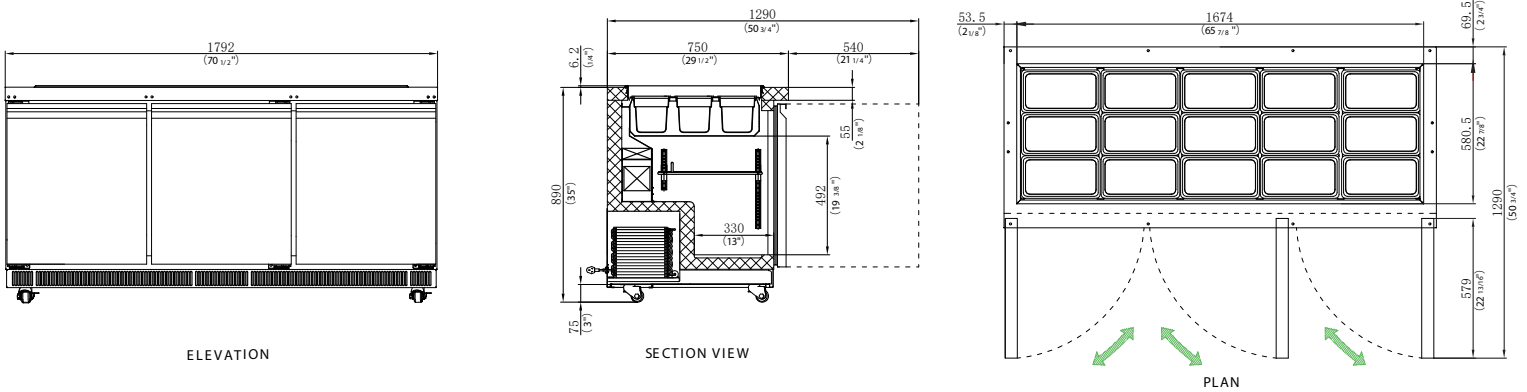

## TECHNICAL SPECIFICATIONS

<b>Item</b>	50090
<b>Model</b>	PT-CN-1778-S-HC
<b>Electrical</b>	110 V / 60 Hz / 1 Ph
<b>Power &amp; Amps</b>	534 W   5.5 Amps
<b>Refrigerant</b>	R290
<b>Max. Ambient Temperature</b>	24°C   75°F
<b>Temperature Range</b>	-0.5 to 0.5°C   31 to 33°F
<b>Isolation Material</b>	Cyclopentane
<b>Cooling System</b>	Ventilated
<b>Number of Doors/Shelves</b>	3   3
<b>Capacity</b>	616 lit. / 21.8 cu. ft.
<b>Shelf Capacity</b>	21.6" x 17.1" (x3)   549 x 434 mm (x3)
<b>Weight</b>	374.8 lb.   170 kg.
<b>Gross Weight</b>	454.2 lb.   206 kg.
<b>Dimensions</b>	70.6" x 29.5" x 34.6"   1792 x 750 x 880 mm
<b>Interior Dimensions</b>	66.6" x 19.8" x 20"   1691 x 503 x 507 mm
<b>Gross Dimensions</b>	73.1" x 32.3" x 43.7"   1857 x 820 x 1110 mm



### Includes:

- Sneeze guard
- Tray slide
- Plastic basin cover
- 15 x 1/3 GN pans or 5 x 1/1 GN pans

## OMCAN INC.

Telephone: 1-800-465-0234  
 Fax: (905) 607-0234  
 Email: sales@omcan.com  
 Website: www.omcan.com



Follow us to keep up to date with the latest news and offers

